

WATER PRESSURE BOOSTER SYSTEMS

SUBMITTAL DATA



Series WPB

APPLICATION

Applications include commercial, industrial, and other installations requiring a boost in water pressure.

FabPro Water Pressure Booster System will efficiently provide a steady downstream pressure regardless of a varying flow rate and/or varying inlet pressure.

DESIGN FEATURES

- Professionally engineered components
- Compact design minimizes floor space
- Single source responsibility
- Factory assembled and tested

PROJECT INFORMATION

Project Name:		Model No. Ordered:
Customer:		Total Capacity:
Engineer:		Boost Pressure:
Reference:		Motor HP:
Date:	PO Number:	Voltage:

WATER PRESSURE BOOSTER SYSTEMS: SERIES WPB

SUBMITTAL DATA

The packaged and tested system shall provide the capacity as scheduled on the drawings. The complete packaged system shall be certified and labeled to NSF/ANSI 61 & 372 standards.

- A. The pump shall be cast iron bronze finished, end suction, close coupled centrifugal type with a minimum of 175 psi case working pressure, equipped with a bronze shaft sleeve and a mechanical seal. The pump shall include a bronze modulating thermal safety valve to prevent overheating of the pump casing.
- B. Each pump shall include a two-piece bronze 600psi WOG non-shock ball valve, isolation valves on the inlet and outlet of each pump to provide service of the pump or control valve, and a spring actuated bronze body check valve.
- C. Provide a NEMA 1 system logic controller mounted and wired to contain:
 - Single point power connection
 - Main disconnect switch with cover interlock
 - Individual motor circuit protectors
 - Variable Frequency Drives, each with a pressure transducer
 - HOA selector switches
 - No flow system shut down
 - Electronic pump alternation
 - Lead pump failure protection
 - Low suction shut down with alarm light
 - High System pressure shutdown with alarm light
 - Remote monitoring contacts
- D. The pump package shall include a 44 gallon hydropneumatic tank mounted and piped on the package. The tank shall also include a pressure relief valve, pressure gauge, and tank isolation valves.
- E. The packaged pumping system shall be factory assembled and tested with type "L" copper piping and shall include pressure gauges. It shall be cleaned and painted with a high grade enamel prior to shipment. The service of a factory trained representative shall be made available on the project site for start-up and instructing operating personnel.

WATER PRESSURE BOOSTER SYSTEMS

SUBMITTAL DATA

Model Number	GPM Each Pump	Pump Head		Pump HP	Header Size SucGon Disch.	Pump Model	Model Number	GPM Each Pump	Pump Head		Pump HP	Header Size SucGon Disch.	Pump Model	
		PSI	Feet						PSI	Feet				
WPB-6020	60	20	45	1.5	2" Simplex	1250	WPB-16020	160	20	45	3	4" Duplex	1550	
6030		30	70	2		1250			16030	30	70		5	1550
6040		40	95	3		1250			16040	40	95		7.5	1550
6050		50	115	5	3" Duplex	1070	16050		50	115	7.5	6" Triplex	1270	
6060		60	140	5		1070			16060	60	140		10	1270
6070		70	160	5		1070			16070	70	160		15	1270
6080		80	185	7.5	3" Triplex	1070	16080		80	185	15		1270	
6090		90	210	7.5		1070			16090	90	210		20	1595
60100		100	231	10		1270			160100	100	231		20	1595
WPB-8020		80	20	45	1.5	2" Simplex	1550		WPB-18020	180	20	45	5	4" Duplex
8030	30		70	3	1550		18030	30			70	5	1550	
8040	40		95	5	1550		18040	40			95	7.5	1550	
8050	50		115	5	3" Duplex	1070	18050	50	115		10	6" Triplex	1570	
8060	60		140	7.5		1070		18060	60		140		10	1570
8070	70		160	7.5		1070		18070	70		160		15	1570
8080	80		185	7.5	3" Triplex	1070	18080	80	185		15		1570	
8090	90		210	7.5		1070		18090	90		210		20	1595
80100	100		231	10		1595		180100	100		231		20	1595
WPB-10020	100		20	45	2	2" Simplex	1550	WPB-20020	200		20	45	3	4" Duplex
10030		30	70	3	1550		20030			30	70	5	2050	
10040		40	95	5	1550		20040			40	95	7.5	1570	
10050		50	115	5	3" Duplex	1070	20050	50		115	10	6" Triplex	1570	
10060		60	140	7.5		1070		20060		60	140		10	1570
10070		70	160	7.5		1070		20070		70	160		15	1570
10080		80	185	10	4" Triplex	1070	20080	80		185	15		1570	
10090		90	210	10		1270		20090		90	210		20	1595
100100		100	231	15		1595		200100		100	231		25	1595
WPB-12020		120	20	45	2	2" Simplex	1550	WPB-25020		250	20	45	5	4" Duplex
12030	30		70	3	1550		25030		30		70	7.5	2070	
12040	40		95	5	1550		25040		40		95	10	2070	
12050	50		115	7.5	3" Duplex	1070	25050	50	115		10	6" Triplex	2070	
12060	60		140	7.5		1070		25060	60		140		15	2070
12070	70		160	10		1070		25070	70		160		15	2070
12080	80		185	10	4" Triplex	1270	25080	80	185		20		2070	
12090	90		210	10		1270		25090	90		210		25	1595
120100	100		231	15		1595		250100	100		231		25	2095
WPB-14020	140		20	45	3	3" Simplex	1550	WPB-30020	300		20	45	7.5	4" Duplex
14030		30	70	5	1550		30030			30	70	10	2070	
14040		40	95	5	1550		30040			40	95	15	2070	
14050		50	115	7.5	3" Duplex	1270	30050	50		115	15	6" Triplex	2070	
14060		60	140	7.5		1270		30060		60	140		15	2070
14070		70	160	10		1270		30070		70	160		20	2070
14080		80	185	10	4" Triplex	1270	30080	80		185	20		2070	
14090		90	210	15		1270		30090		90	210		30	2095
140100		100	231	15		1595		300100		100	231		30	2095

Note: SelecGons are 3500 RPM.

Header opGons:

304 Schedule 40 Stainless Steel
Class 125/150 ANSI Fanged
Grooved

WATER PRESSURE BOOSTER SYSTEMS

SUBMITTAL DATA

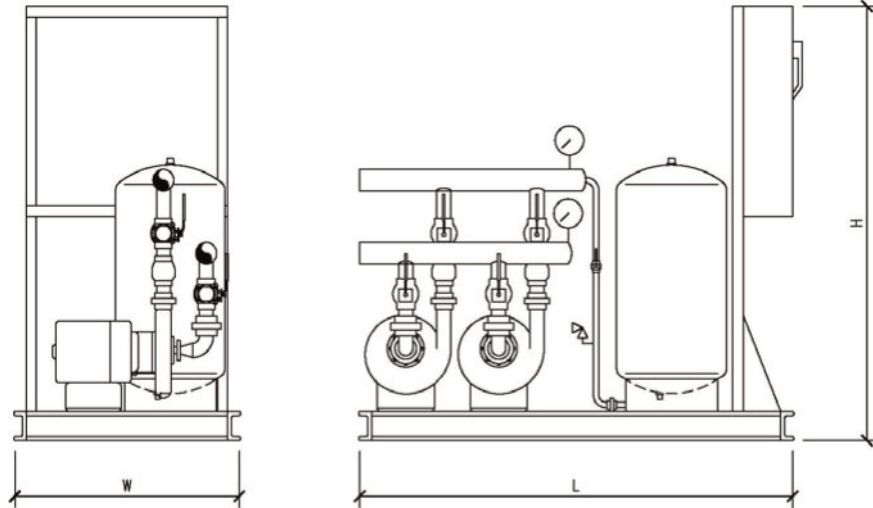

**SYSTEM DIMENSIONS
DUPLEX**

HP Per Pump	L x W x H (inches)	Dry Wgt. (Lbs.)
1.5 - 7.5	72 x 34 x 60	1300
10 - 15	78 x 34 x 60	1450
20 - 30	84 x 40 x 60	1700

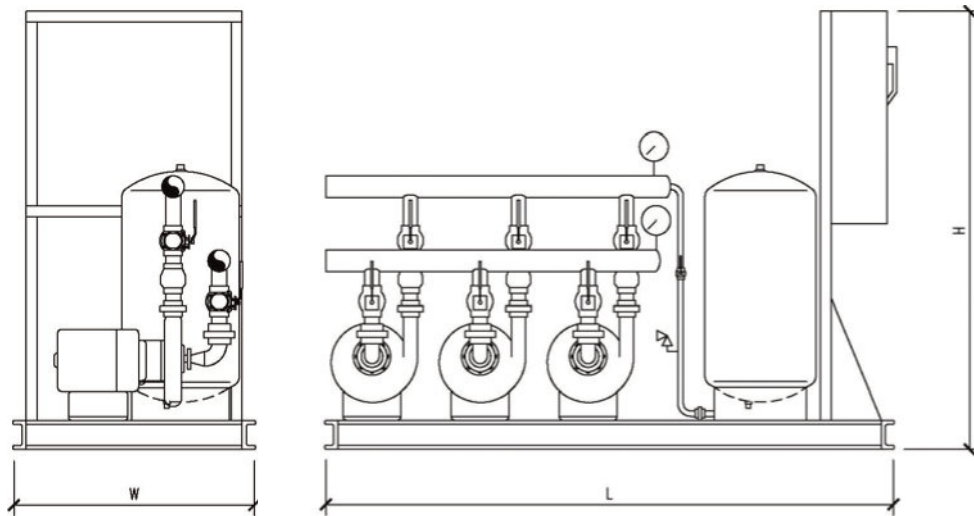

**SYSTEM DIMENSIONS
TRIPLEX**

HP Per Pump	L x W x H (inches)	Dry Wgt. (Lbs.)
1.5 - 7.5	90 x 34 x 60	1600
10 - 15	96 x 34 x 60	1900
20 - 30	108 x 40 x 60	2250

SUBMITTAL DATA

CENTRIFUGAL PUMPS



DESIGN FEATURES

Cast Iron Bronze finished construction
Back pull out design
Compact design minimizes floor space
Factory assembled and tested
Built according to Hydraulic Institute – NEMA Standards

STANDARD CONSTRUCTION

Cast Iron Casing
Bronze Impeller
Carbon Steel Shaft
Bronze Shaft Sleeve
Bronze Case Wear Ring
Open Drip-Proof Motor
Single Mechanical Seal
Maximum Working Pressure 175 PSI

OPTIONS

TEFC or Explosion-Proof Motors
High Temperature Seals
Special Alloy Shaft Seals
Higher Working Pressure

WATER PRESSURE BOOSTER SYSTEMS

SUBMITTAL DATA



The integrated pump specific software and setup parameters, allow the operator to set up specific control values for a wide range of applications. pump will automatically adjust pump operating conditions, as the process variables change while still maintaining optimum pump performance and protection.

Most existing systems, which require constant pressure or flow control, are using bypass lines, pressure release valves, throttling valves or impeller trim adjustments. The most efficient method is pump speed control. Pump speed control will reduce energy consumption, while maintaining system optimization.

The pump Controller can be configured for Simplex, Duplex, Triplex or up to an eight-pump system. One pump Controller can be used as a master, which can also control one or two secondary pump motors. The secondary pump motors can be connected using mechanical motor starters, reduced voltage soft starters, or additional IQPump drives. The software is structured in such a way that it only has a few basic pump parameters to be setup to run this application.

The pump controller is available from 5 to 500 horsepower. In addition to Water Pressure Booster Pumps in Commercial and Industrial application, the pump controller is suitable for a variety of other pumping applications such as Submersible Deep Well Pumps, Storage Tank Level Control, Metering Pumps, and HVAC pumps and fans.

Drive Performance Features

- Ratings: 5-150 HP, 208 VAC 5-150 HP, 230 / 240 VAC 5-500 HP, 480 VAC
- Overload capacity: nominal 110% for 60 sec. (150% peak)
- Starting torque: 100% at 3 Hz
- Motor preheat function
- Adjustable accel/decel: 0.1 to 6000 sec.
- Controlled speed range: 40:1
- Critical frequency rejection: 3 selectable, adjustable bands
- Torque-limiting: 30-180%
- Energy Saving control
- Torque boost: full range, auto
- Power loss ride-thru: 2 sec.
- Auto restart after power loss or fault reset, selectable, programmable
- Feedback signal loss detection
- Serial communications loss detection
- "Up/Down" floating point control capability (PI)
- Stationary motor auto-tuning
- Pump Sleep function
- Run-permissive input

Pump Control Features

- Operator Keypad with intuitive pump language
- Hand-Off-Auto
- Programmable Pump Process Set Point
- Pump Start Level & Start Time
- Sleep Protection
- Simplex, Duplex, & Triplex Control
- Automatic System Restart
- No Flow Detection
- Low and High Feedback set points
- Pre-Charge Low Level Control
- Thrust Bearing Control
- Automatic System Stabilization
- Motor Condensation Pre-Heat Function

Protective Features

- Current-limited stall prevention
- Heat sink over-temperature, speed fold-back
- Bi-directional start into rotating motor
- Current-limiting DC bus fuse
- Optically-isolated controls
- Short circuit protection: Phase-phase and phase-neutral
- Ground fault protection
- Short circuit withstand rating: 100K RMS
- Electronic motor overload: UL
- Current limit
- Fault display: last 10 faults
- Fault circuit: OC, OV, OT
- Over torque and under torque protection

Pump Protective Features

- Dry Well
- Air in System
- Blocked Impeller
- Pump over Cycling
- No Flow Protection
- Loss of Prime
- Transducer Loss
- Over Torque

Pump Alarms and Messages

- Low Feedback
- High Feedback
- Low Level
- Low Water
- Pump Over Cycling
- No Flow Detection
- Loss of Prime
- Pump Fault
- Motor Thermostat
- Pre-Charge Mode
- Thrust Bearing Active
- Start Mode Active
- Sleep Mode Active

Service Conditions

- Ambient Temperature:
 - -10°C to 40°C (14° F to 104° F) NEMA 1,
 - -10°C to 45°C (14° F to 113° F) protected chassis
- Humidity: 95% RH, non-condensing
- Altitude: 3300 ft; higher by derate
- Input voltage: +10%/-15%
- Input frequency: 50/60 Hz ± 5%
- 3-phase, 3-wire, phase sequence insensitive

Design Features

- LCD keypad display, 5 lines x 16 characters, backlit, 6 languages, copy function
- Multi-step speed settings: 5 available
- Setpoint (PI) control
- 32-bit microprocessor logic
- Non-volatile memory, program retention
- Displacement power factor: 0.98
- Output frequency: 0.1 to 120 Hz
- Frequency resolution: 0.06 Hz
- Frequency regulation: 0.1%
- Control Terminal Board: Quick disconnect
- Carrier frequency: selectable to 15 kHz
- 3% DC bus reactor: 30-150 HP, 208 VAC; 30-150 HP, 240 VAC; 40-500 HP, 480 VAC; optional on lower ratings
- 24 VDC control logic, PNP / NPN selectable
- Transmitter/Option power supply
- Input/output terminal status
- Timer function: Elapsed Time, Delay on start, Delay on stop
- RS-422/485 port: Modbus protocol
- Volts/hertz ratio: Preset and programmable V/Hz patterns
- Meter Functions: Volt, amp, kilowatt, elapsed run time, speed command
- NEMA 1 or protected chassis
- UL, cUL listed and CE marked; IEC 146;
- MTBF: exceeds 28 years

WATER PRESSURE BOOSTER SYSTEMS

TYPICAL POWER CIRCUIT WIRING

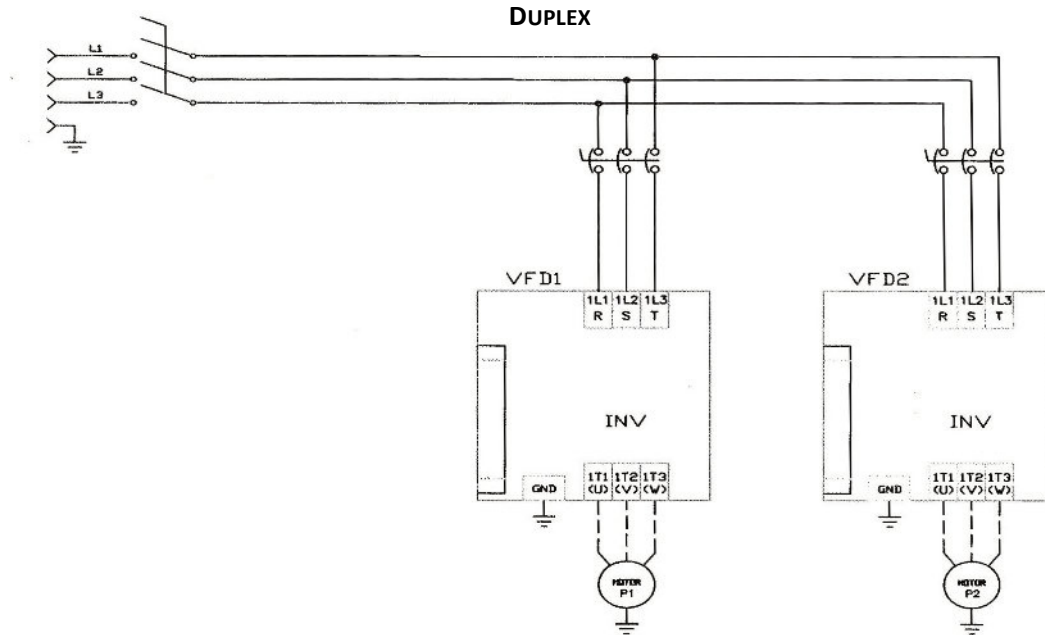

APPROXIMATE FULL LOAD AMPS PER MOTOR

Voltage	Horsepower									
	1 ½	2	3	5	7 ½	10	15	20	25	30
200	4.6	6.2	7.0	15.4	21.8	28.8	42.1	57.5	69.7	83.5
230	4.2	5.4	7.8	13.3	19.0	25.0	36.5	50.0	60.5	72.5
460	2.1	2.7	3.9	6.7	9.5	12.5	18.3	25.0	30.3	36.3

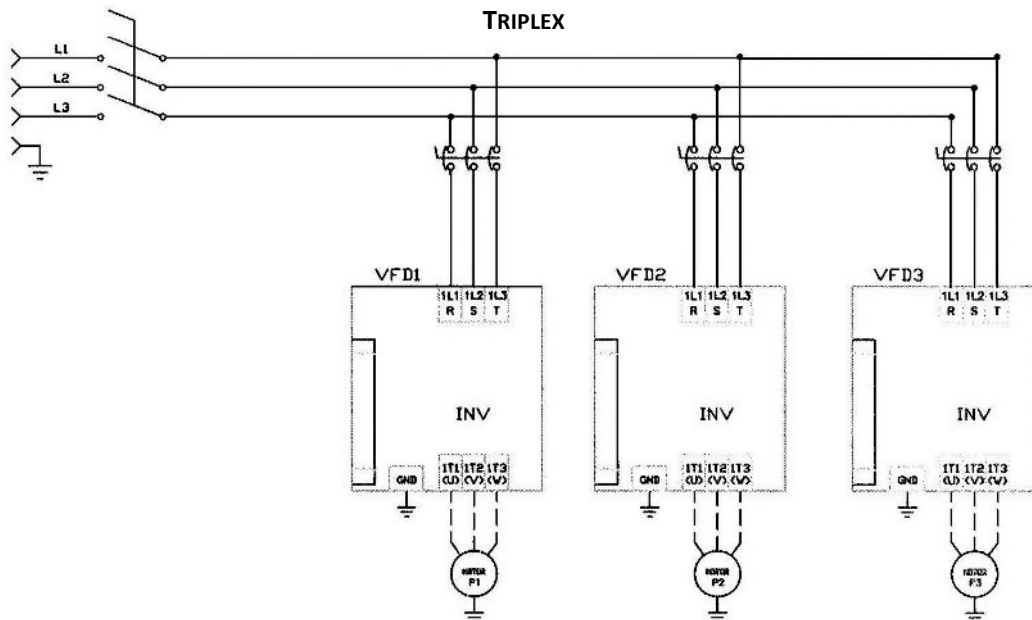

WATER PRESSURE BOOSTER SYSTEMS

SUBMITTAL DATA

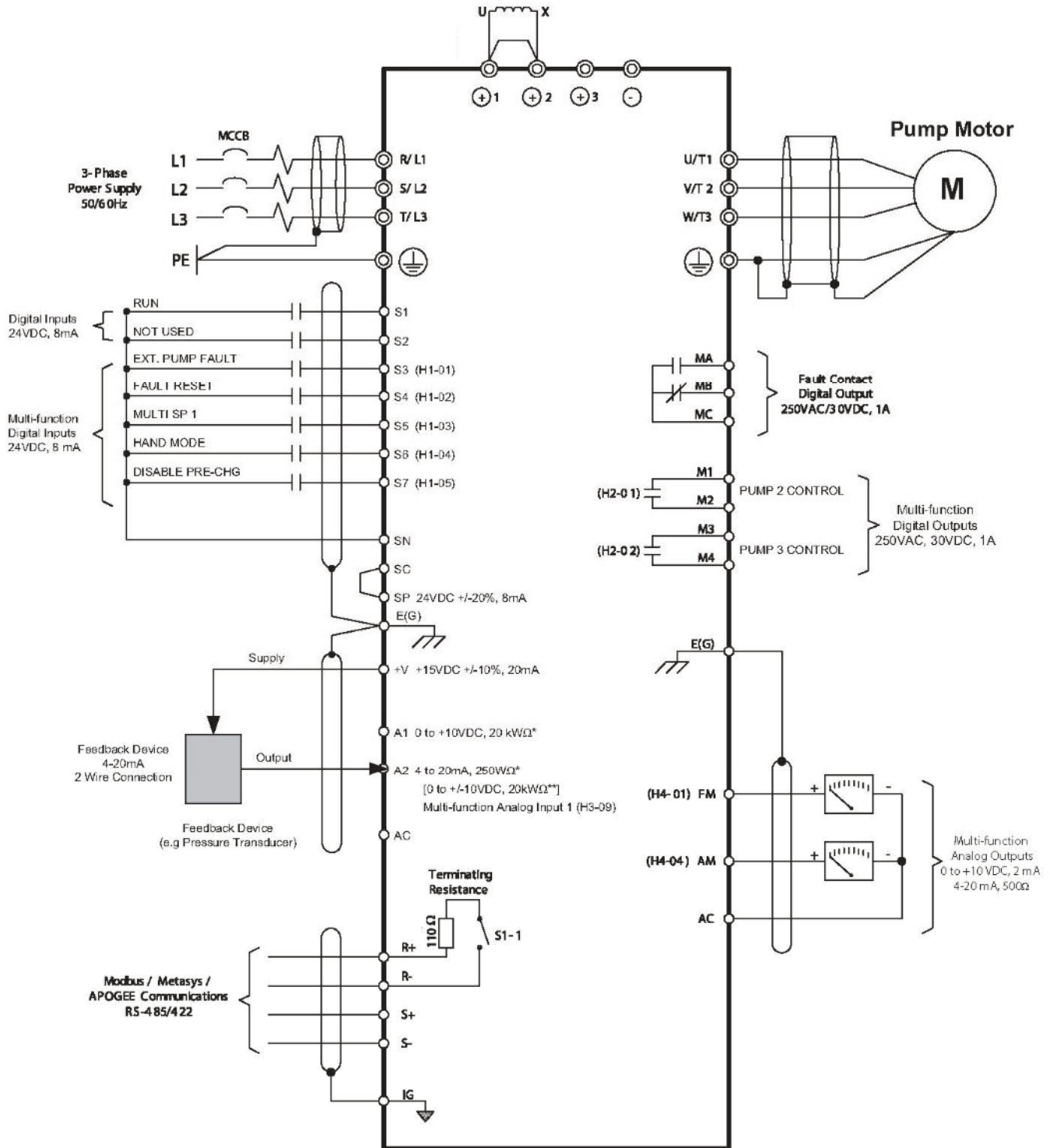

WATER PRESSURE BOOSTER SYSTEMS

SUBMITTAL DATA



FULL PORT, TWO PIECE, BRASS BALL VALVE

Body	Brass
Ball	Chrome plated brass
Seat	PTFE
Pressure Rating	600 PSI



LUG STYLE BUTTERFLY VALVE

Body	Ductile Iron
Stem	416SS
Disc	Aluminum Bronze
Seat	EPDM
Pressure Rating	200 PSI

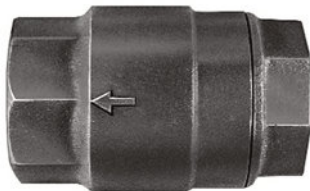

BRONZE SILENT CHECK VALVES

Body	Bronze
Seat	PTFE
Spring	Stainless Steel
Pressure Rating	250 PSI



WAFER TYPE CHECK VALVE

Body	Cast Iron ASTM A126-B
Trim	Bronze ASTM B62/316 SS
Spring	302 Stainless Steel, ASTM A276
Pressure Rating	250 PSI

WATER PRESSURE BOOSTER SYSTEMS

SUBMITTAL DATA



HYDRO-CUSH TANK

Capacity	44 Gallons Standard	86 Gallons Optional
System ConnecGon	Stainless Steel	
Diaphragm	Butyl	
Liner	Polypropylene	
Pressure RaGng	150 PSIG	



PRESSURE RELIEF VALVE

Body	Bronze
Seat	Bronze
Valve	Stainless Steel
Pressure RaGng	150 PSIG



THERMAL PURGE VALVE

Body	Brass
Seat	Brass
Spring	300 Series Stainless Steel
Seal	Buna-N
Pressure RaGng	300 PSIG
Set Temperature	105°F



PRESSURE GAUGE

Case	Stainless Steel
Bourdon Tube	Brass
Size	4 ½" Dial
Face	Glass